



GAI-TRONICS®
A HUBBELL COMPANY

Model 540-001 LED Strobe with Constant-On Feature

Confidentiality Notice

This manual is provided solely as an installation, operation, and maintenance guide, which contains sensitive business and technical information that is confidential and proprietary to GAI-Tronics. GAI-Tronics retains all intellectual property and other rights in or to the information contained herein, and such information may only be used in connection with the operation of your GAI-Tronics product or system. This manual may not be disclosed in any form, in whole or in part, directly or indirectly, to any third party.

General Information

The Model 540-001 LED Strobe features a constant-on with flashing operation and a secondary contact closure output for auxiliary equipment control. The glow of the LED tower remains constant for area location and flashes at a rate of 240 flashes per minute when activated by a GAI-Tronics Emergency Telephone.

The Model 540-001 is equipped with a 3/4-inch NPT female pipe thread in its base, permitting mounting directly to GAI-Tronics' Model 234, 240, or 241 series stanchions. It can also be wall-mounted utilizing a Model 4115A Mounting Bracket.

⚠ WARNING ⚠ Research indicates that a small portion of the general population, (approximately 1 in 100,000) with Photosensitive Epilepsy (PSE) may experience epileptiform seizures upon exposure to certain visual stimuli including lights flashing in excess of 3Hz (180cpm). Individuals with positive photic response to visual stimuli who are prone to seizures, such as persons with epilepsy, should avoid prolonged exposure to environments in which flashing lights are activated.

Installation

⚠ CAUTION ⚠

These installation instructions are for use by qualified service personnel only.

- All field wiring to the strobe must meet the requirements of the National Electric Code (NEC) and any other applicable local or state codes.
- Before beginning any installation or modification, be sure the main electrical disconnect switch is in the OFF position. TAG THE DISCONNECT SWITCH WITH A SUITABLE WARNING LABEL.
- Electrical ground is required on this appliance.
- Improper connection of the equipment can result in electrical shock.

Mounting

Attach the model 540-001 LED strobe utilizing the female 3/4 inch NPT threads located on the bottom of the strobe base. Thread the strobe onto the conduit making sure the strobe is adequately tightened for sealing. For GAI-Tronics custom equipment installations, refer to the installation and operation manual included with that product.

Model 234 Stanchion Mounting: When mounting the model 540-001 to a Model 234 Series stanchion, a 3/4-inch by 3/4-inch M/F extension is provided for optional installation. The extension increases the installation height of the LED Strobe for maximum visibility. See Figure 1

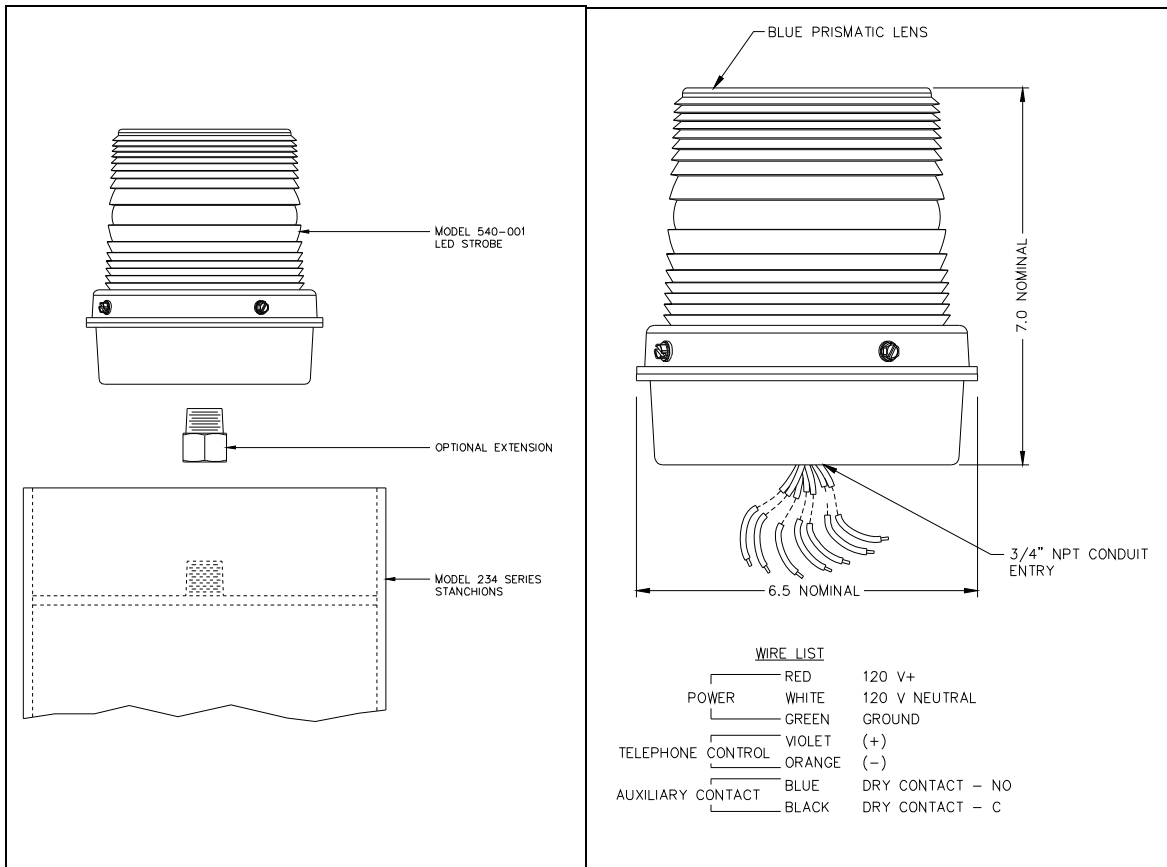

Figure 1. Installation of Optional Extension

Figure 2. Model 540-001 LED Strobe Outline

Wiring

The Model 540-001 LED Strobe is equipped with seven 15-foot conductor leads. Refer to Figure 2. The red (120 V ac line) and white (120 V ac neutral) leads are connected to the 120 V ac power source. The green lead is the earth ground wire.

The violet (+) and orange (-) leads are connected to the emergency telephone to signal the strobe to flash. The blue and black leads are provided to activate auxiliary equipment.

1. Connect the red (line) lead to the local power source.
2. Connect the white (neutral) lead to the local power source.

Warranty

Equipment. GAI-Tronics warrants for a period of one (1) year from the date of shipment, that any GAI-Tronics equipment supplied hereunder shall be free of defects in material and workmanship, shall comply with the then-current product specifications and product literature, and if applicable, shall be fit for the purpose specified in the agreed-upon quotation or proposal document. If (a) Seller's goods prove to be defective in workmanship and/or material under normal and proper usage, or unfit for the purpose specified and agreed upon, and (b) Buyer's claim is made within the warranty period set forth above, Buyer may return such goods to GAI-Tronics' nearest depot repair facility, freight prepaid, at which time they will be repaired or replaced, at Seller's option, without charge to Buyer. Repair or replacement shall be Buyer's sole and exclusive remedy. The warranty period on any repaired or replacement equipment shall be the greater of the ninety (90) day repair warranty or one (1) year from the date the original equipment was shipped. In no event shall GAI-Tronics warranty obligations with respect to equipment exceed 100% of the total cost of the equipment supplied hereunder. Buyer may also be entitled to the manufacturer's warranty on any third-party goods supplied by GAI-Tronics hereunder. The applicability of any such third-party warranty will be determined by GAI-Tronics.

Services. Any services GAI-Tronics provides hereunder, whether directly or through subcontractors, shall be performed in accordance with the standard of care with which such services are normally provided in the industry. If the services fail to meet the applicable industry standard, GAI-Tronics will re-perform such services at no cost to buyer to correct said deficiency to Company's satisfaction provided any and all issues are identified prior to the demobilization of the Contractor's personnel from the work site. Re-performance of services shall be Buyer's sole and exclusive remedy, and in no event shall GAI-Tronics warranty obligations with respect to services exceed 100% of the total cost of the services provided hereunder.

Warranty Periods. Every claim by Buyer alleging a defect in the goods and/or services provided hereunder shall be deemed waived unless such claim is made in writing within the applicable warranty periods as set forth above. Provided, however, that if the defect complained of is latent and not discoverable within the above warranty periods, every claim arising on account of such latent defect shall be deemed waived unless it is made in writing within a reasonable time after such latent defect is or should have been discovered by Buyer.

Limitations / Exclusions. The warranties herein shall not apply to, and GAI-Tronics shall not be responsible for, any damage to the goods or failure of the services supplied hereunder, to the extent caused by Buyer's neglect, failure to follow operational and maintenance procedures provided with the equipment, or the use of technicians not specifically authorized by GAI-Tronics to maintain or service the equipment. **THE WARRANTIES AND REMEDIES CONTAINED HEREIN ARE IN LIEU OF AND EXCLUDE ALL OTHER WARRANTIES AND REMEDIES, WHETHER EXPRESS OR IMPLIED BY OPERATION OF LAW OR OTHERWISE, INCLUDING ANY WARRANTIES OF MERCHANTABILITY OR FITNESS FOR A PARTICULAR PURPOSE.**

Return Policy

If the equipment requires service, contact your Regional Service Center for a return authorization number (RA#). Equipment should be shipped prepaid to GAI-Tronics with a return authorization number and a purchase order number. If the equipment is under warranty, repairs or a replacement will be made in accordance with the warranty policy set forth above. Please include a written explanation of all defects to assist our technicians in their troubleshooting efforts.

Call 800-492-1212 (inside the USA) or 610-777-1374 (outside the USA) for help identifying the Regional Service Center closest to you.